

O-CE7-0SYZXX-X-X-XX-X-5.000 MHz
Precision Ultra Low Phase Noise OCXO in 36x27 mm “Europack”

Product Data Sheet

Features

- SC-cut crystal
- High Stability
- Low Aging
- Ultra Low Phase Noise Option:
 - Standard(L) -145dBc/Hz at 10Hz;
-172dBc/Hz on the floor
 - Premium(P) -150dBc/Hz at 10Hz;
-173dBc/Hz on the floor
 - Ultimate(U) -120dBc/Hz at 1 Hz
-151dBc/Hz at 10Hz;
-174dBc/Hz on the floor
 - Extraordinary(E) -125 dBc/Hz at 1 Hz
-153 dBc/Hz at 10 Hz
-174 dBc/Hz on the floor
- Sine Wave or HCMOS/TTL output

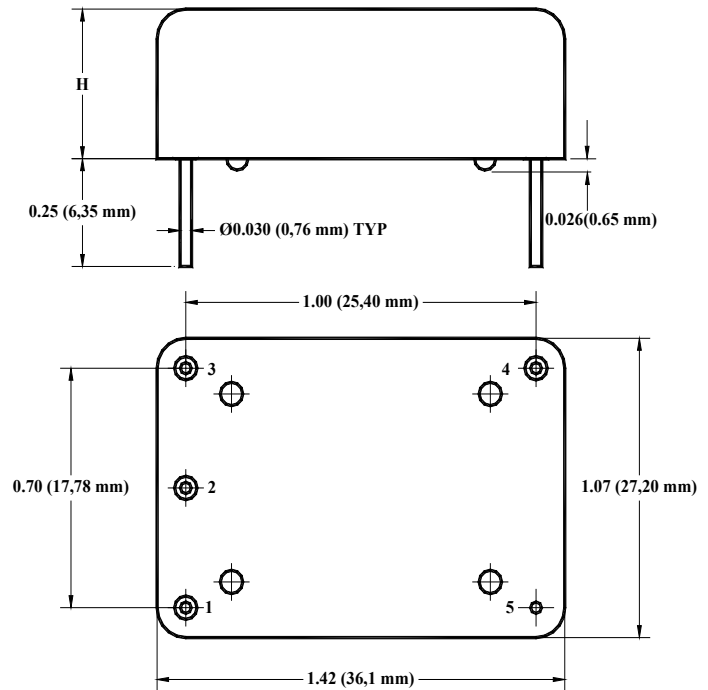

Applications

- Instrumentation
- GPS
- Test and Measurement
- Radar
- COTS/Dual use

Height code H = 7 for height 0.75” (19 mm)

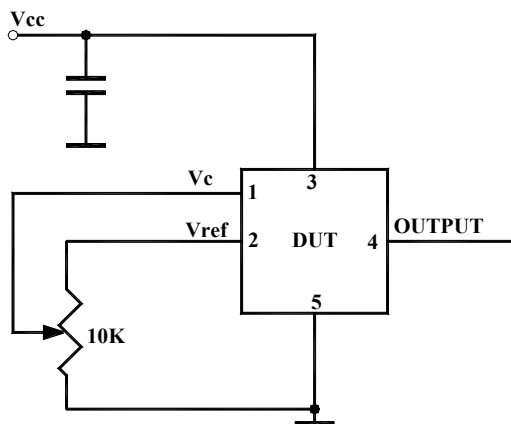

Parameter	Symb	Condition	Min	Typ	Max	Unit	Note
Absolute Maximum Ratings							
Input Break Down Voltage	V _{cc}	5 V supply	-0.5		5.5	V	
Storage temper.	T _s		-50		90	°C	
Control Voltage	V _c		-1 -5 -1		5.5 5 11	V	Slope option "P" Slope option "N" Slope option "L"
Electrical (6)							
Frequency	F			5.000		MHz	
Frequency stability	ΔF/F	vs. Temp.		±20		ppb	See chart below
		vs. Supply		0.2	0.3	ppb/10%V _{cc}	
Aging		per day		5E-10			after 30 days 5E-8 available
		per year, first year		1E-7			
		second year		3E-8			
		10 years		2.5E-7			
		15 years		2.7E-7			
Allan Deviation		0.1s		5E-13			Premium version, Option "P"
		1s		2E-12			
		10s		5E-12			
SSB Phase Noise (achieved after 10 minutes warm-up)		1Hz		-110		dBc/Hz	Standard version, option L
		10 Hz			-145		
		100 Hz			-160		
		1 KHz			-167		
		10 KHz			-172		
		100 KHz			-172		
		1Hz			-117		Premium version, option P
		10 Hz			-150		
		100 Hz			-160		
		1 KHz			-167		
		10 KHz			-173		
		100 KHz			-173		
		1Hz			-120		Ultimate version, option U
		10 Hz			-151		
		100 Hz			-161		
		1 KHz			-168		
		10 KHz			-173		
		100 KHz			-173		
		1Hz			-125		Extraordinary version, option E, available with slope options N or L
		10 Hz			-153		
	100 Hz			-165			
	1 KHz			-172			
	10 KHz			-173			
	100 KHz			-173			
Retrace		After 30 minutes			±10	ppb	24 Hours off 3*
G-sensitivity		worst direction			±1.0	ppb/G	
Input Voltage	V _{cc}		4.75	5.0	5.25	V	
Power consumption, Still air	P	steady state, 25°C		1.0	1.4	W	Standard Operating Temperature*
		steady state, -30°C		1.7			
		start-up @ -30°C		2.5	3.2		
Spectral Purity		Subharmonics		none		dBc	
		Spurious			-80		
		Harmonics		-35	-30		
Load	AC-coupled 50 Ohm (Sine-wave)						
Warm-up time	τ	to 0.1ppm accuracy		3	5	minutes	
Output Waveform	Sinewave						



Output Power			+10	+13		dBm	Output Code S
Control voltage	Vc		0 -4.0 0		Vref 4.0 10.0	V	Slope option "P" Slope option "N" Slope option "L"
Input impedance	Zin	At Vc pin	10			KOhm	
Modulation bandwidth	Fm		DC		1	KHz	
Reference Voltage	Vref			4.5		V	N/A with slope options "N" and "L"
Output Impedance		At Vref pin		100		Ohm	
Pull range		from nominal F	±0.4	±0.6		ppm	
Deviation slope		Monotonic, positive Monotonic, negative Monotonic, positive		1.2/Vref -0.15 0.14		ppm/V	Slope option "P" Slope option "N" Slope option "L"
Setability	Vc0	@25°C, Fnom. No internal bias for slope option "L"	Vref/2 ± 0.5 0 ± 0.5 5 ± 0.5			V	Slope option "P" 3* Slope option "N" Slope option "L"

Notes:

- *. For highest operating temperature higher than 70°C the power consumption will be higher (about 20% for 85°C). Values listed are for test in still air environment, the values will go up while testing in the temperature chamber.
- 3*. Longer storage time, especially at low temperatures, may affect both retrace and setability parameters. It may require few days on power for re-stabilization.
- 5*. Pin 2 is connected to Vref only for Slope Option "P".
- 6. All parameters, unless otherwise specified, are at nominal conditions, i.e.: T=25°C, Nominal Vcc & Nominal Load.

Environmental and Mechanical

Operating temp. range	0°C to 70°C Standard, Other options – see chart below
Storage Temperature	-50°C to 90°C
Mechanical Shock	Per MIL-STD-202, 30G, 11ms
Vibration	Per MIL-STD-202, 5G to 2000 Hz
Soldering Conditions	260°C for 10s Max leads only

Electrical Connections

Pin Out	Pin #1-Vc ; Pin#2 – Vref or N/C (5*); Pin #3 – Vcc; Pin #4- Output ; Pin #5- GND;
----------------	---



Creating a Part Number

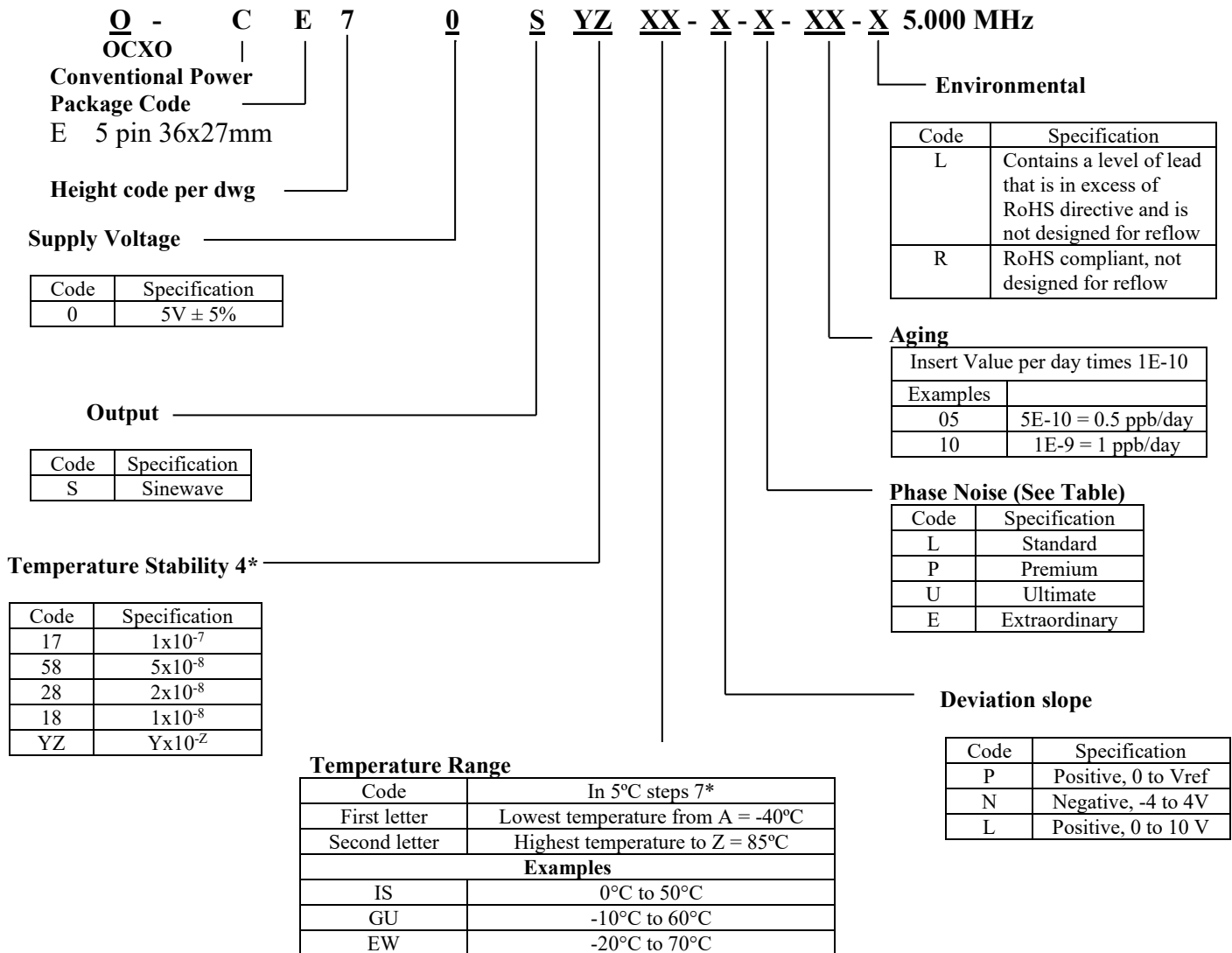

Not all combinations are available. Consult Factory.

7*Temperature Code Table

Letter	Temp °C	Letter	Temp °C	Letter	Temp °C	Letter	Temp °C	Letter	Temp °C	Letter	Temp °C
A	-40	F	-15	K	10	P	35	U	60	Z	85
B	-35	G	-10	L	15	Q	40	V	65		
C	-30	H	-5	M	20	R	45	W	70		
D	-25	I	0	N	25	S	50	X	75		
E	-20	J	5	O	30	T	55	Y	80		



FREQUENCY CONTROLS, INC.